

The result of continuous innovation by GYS, the GYSPOT PTI GENIUS Plus revolutionises spot welding. Fully automated and ultra-ergonomic, it combines a lightweight clamp with pneumatic over-opening, simplified arm positioning, and an extended motorised overhanging balancing system offering unrivalled mobility and accessibility. Its patented cable locking system makes it easy to detach the clamp quickly. Its new 7" colour interface offers a clear display and intuitive navigation, optimising configuration and operation on a day-to-day basis.

HIGH PERFORMANCE

- **High duty cycle** with max. 14,500 A welding current, ideal for welding all types of steel on modern vehicles (HSS/VHSS, UHSS and Boron).
- **Liquid-cooled** (7.9 US gal) transformer, electrodes, and caps for maximum productivity.
- **High speed** (15 spots/min).
- Clamping force up to **600 daN** at 116 psi to meet OEM requirements.
- **Clamp with integrated transformer**, reducing power consumption to a minimum (50 A fuse).

ADJUSTABLE BALANCING SYSTEM

- Offset by **55 inch** of the power source for improved range.
- **Motorised boom arm** to adjust height to accommodate vehicle dimensions.
- **Cable lock** for easy clamp release (GYS patent).
- Counterbalance to relieve the weight of the clamp, away from the working area.
- 90° folding boom arm to optimise space.
- Rubber protectors on the ends of moveable parts.

EASY TO USE

- **Automatic mode:** the intelligent clamp detects the correct welding parameters automatically.
- **Pneumatic over-opening** for 3 inch clearance between the 2 caps.
- Improved user interface with **large 7" colour screen**.
- Easy to use for all automotive repair professionals.
- Spot counter to determine the service life of the caps.

ERGONOMIC

- Reinforced, easy-to-maneuvre trolley with 7.9 US gal coolant tank.
- **Compact clamp** (27.3 lbs) with 360° rotation via a built-in gyroscope.
- 19 ft interconnection cable between clamp and machine for improved access to all areas of the vehicle. The interconnection cable can be disconnected for easier maintenance of the clamp.
- Expander on the front wheels for greater stability.
- Integrated 9-arm support.

PREMIUM G-ARMS

- Quick and easy to change the welding arms, no tools required.
- **Brass clamp holder** and arm foot plate for optimum electrical contact.
- **Automatic connection** of coolant terminals.
- Wide range of optional arms for full vehicle access.

OPTIMISED TRACEABILITY

- **Traceability** of spot welds, with data export via USB for reporting.
- Complete machine **updates** via USB stick.

OPTIONAL ACCESSORIES

- Quick Fix single-point gun kit (082823)
- [G arms and consumables](#)

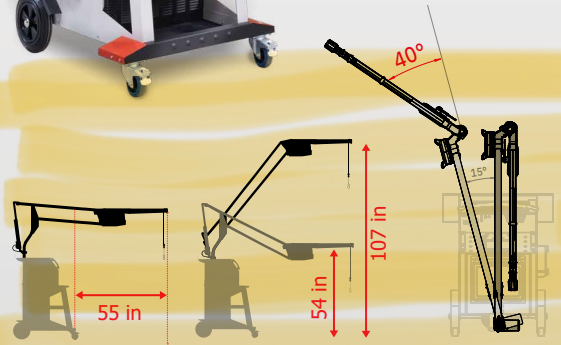

Double action lever
- arm change
- mechanical over-opening

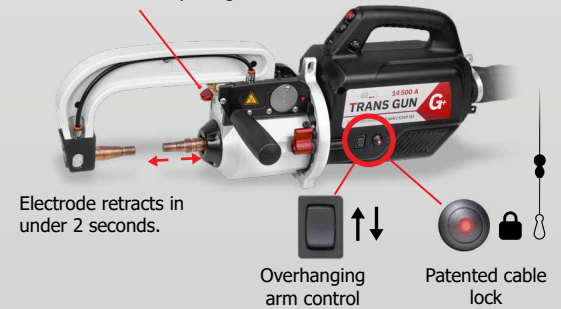

Three-phase 50/60 Hz	A D-type	Spots / min (max.)	I RMS A	inch		27.3 lbs	Cables			Liquid	inch	lbs
				0.1+0.1+0.1	0.06+0.12		(optional)	(optional)	(optional)			
200 > 240 V	50	15	12 500 > 14 500	0.1+0.1+0.1	0.06+0.12	27.3 lbs	5.9 ft	3.3 ft	26 ft	7.9 US gal	28 x 35 x 78	220